



Automatic Tire Chains

Vehicle Suspension Information

FORM #3130009 Side 1 of 2

The following information and measurements are required in order to determine if the vehicle can be fit with Onspots, and, if so, which Model Onspot Chain Set and Mounting Bracket Kit is required. This information will be different from vehicle to vehicle based on vehicle make/model, axle make/model, tire size, and wheel offset. Any questions in completing this form can be addressed to Onspot at 800-224-2467. OEM NOTE: Please indicate if chassis has no body.

Dealer or OEM name: _____

Customer name: _____ Ref. Unit No. _____

Address: _____

City: _____ State: _____ Zip: _____

Contact: _____ Phone Number: _____

Quantity of identical vehicles for this order: _____

Description: (School Bus, Service Truck, etc.) _____

Vehicle Make: _____ Model: _____ Year: _____

Note: The following information applies to the rear suspension only.

Axle Make: _____ Capacity: _____ Tandem/Single

Axle Speed: Single/Two Tire Size: _____ Brand: _____

Air Brakes: Yes/No Air brake cylinder location: Front/Back

Disc Brakes: Yes/No Suspension Type: Spring/Air/Other: _____

Shock on rear axle: Yes/No Shock location on rear axle: Front/Back

Shock bracket: Yes/No If yes, Shock bracket thickness (in.): _____

Torsion/Sway Bar: Yes/No Sway bar location: Front/Back

Are there any obstructions within 36" in front of or behind rear axle that would prevent the Onspot Installation? (ie. Fuel tank, air tank, exhaust, driveline retarder, cabinets, etc.)

If so indicate item and distance from AXLE, from GROUND, and from TIRE SIDEWALL.

VEHICLE SUSPENSION INFORMATION FORM #3130009

(A) The distance from the lowest part of the saddle plate to where the u-bolt nut contacts the saddle plate.
NOTE: This dimension does not apply to all axles.

(BF) The distance from the ground to where the front u-bolt nuts contact the saddle plate.

(BB) The distance from the ground to where the rear u-bolt nuts contact the saddle plate.
NOTE: If the BB or BF measurements are to the bottom of a shock bracket that is held in place by the u-bolt nuts, PLEASE INDICATE.

(C) The distance from the tire bulge (approximately 3 1/2 – 4 inches off the ground) to the center of the u-bolt closest to the tire. This measurement is best taken by hanging a plumb bob from the CENTER of the u-bolt and measuring to the tire bulge.

(D) The thread remaining below the u-bolt nuts (in inches).

(E) The thickness of the u-bolt nut (and washer if applicable).

(X) The diameter of the u-bolt. Fine or Coarse thread.
CAUTION: Some u-bolts may be metric.

(Y) The center to center distance of the u-bolts front to back.

(Z) The center to center distance of the u-bolts side to side.

(GB) The distance from the ground to the LOWEST POINT of the brake chamber.

(SB) The distance from the tire sidewall to the CENTER of the brake chamber.

(UB) The distance from the FRONT U-BOLT to the brake chamber.

NOTE: The GB, SB, and UB measurements are to the SAME REFERENCE POINT on the air brake chamber.

QUESTIONS?? 1-800-224-2467

FAX COMPLETED FORM TO: 812-346-1819

Side 2 of 2

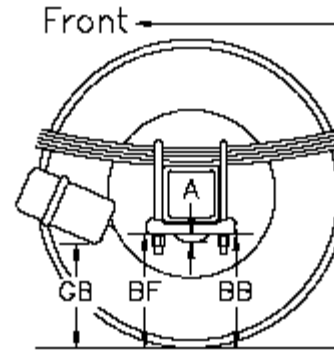

Side View

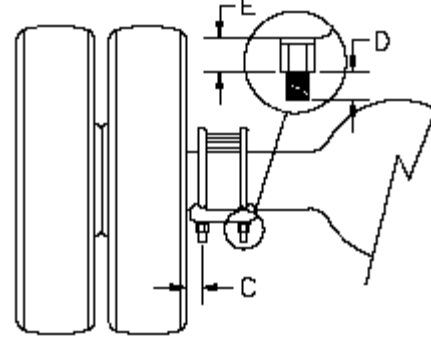

End View

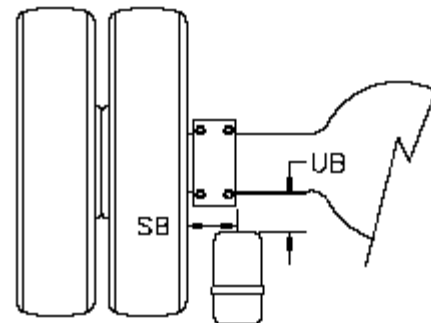

Bottom View

Depth of Round A = _____

Height in Front BF = _____

Height in back BB = _____

Sidewall Distance C = _____

Remaining U-bolt D = _____

Nut Height Thickness E = _____

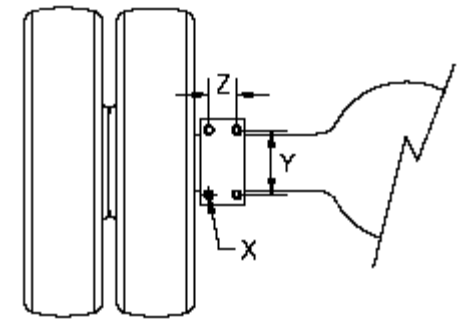

Bottom View

U-Bolt Diameter X = _____ Fine/Coarse

Distance Front to Rear Y = _____

Distance Side to Side Z = _____

Brake Chamber to Ground
GB = _____

Brake Chamber to Tire
SB = _____

Brake Chamber to Front U-Bolt
UB = _____